

 **OMEGA**[®]
FOODTECH

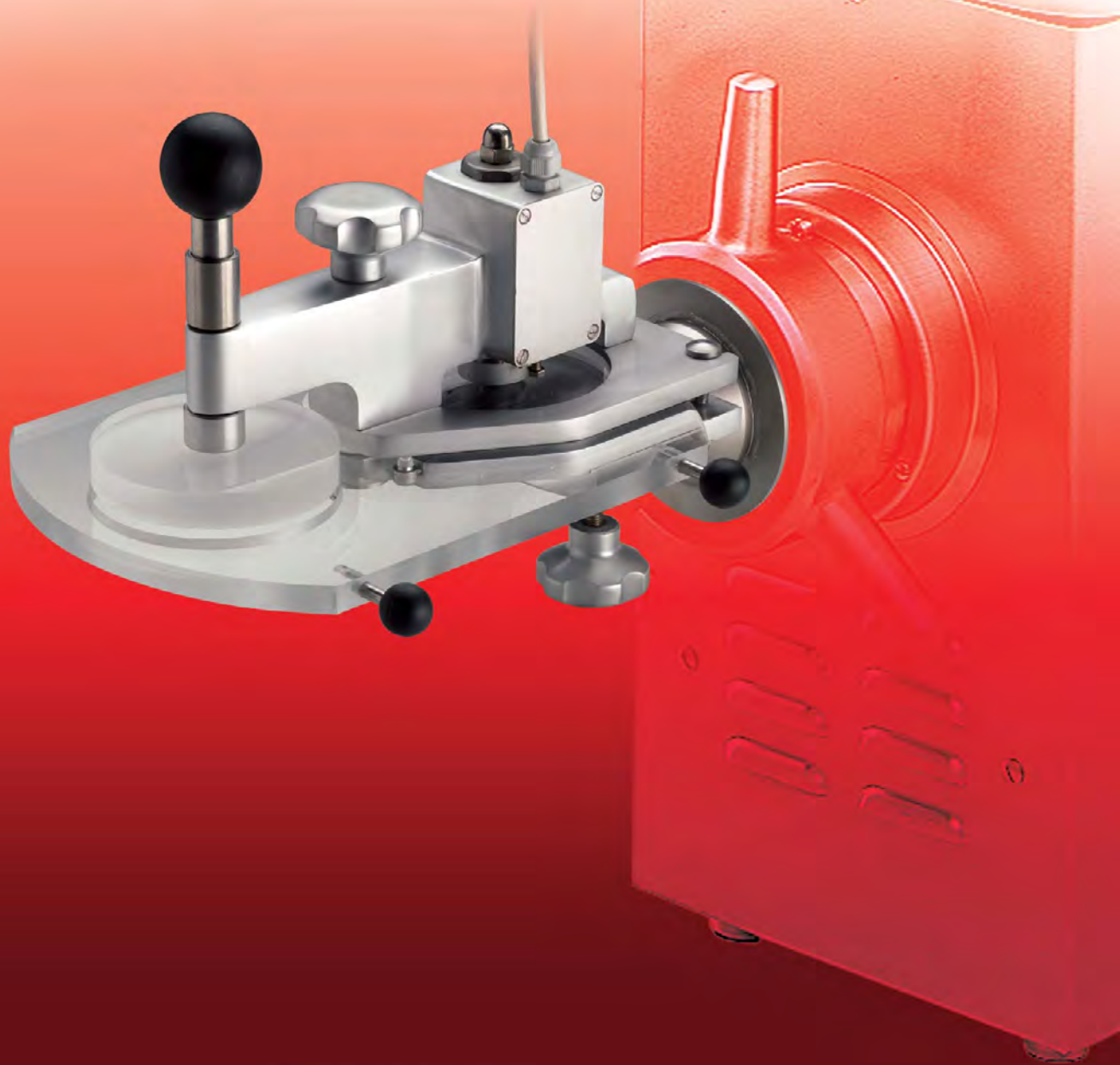

PH A



PORZIONATRICE SEMIAUTOMATICA

- PH A 4: connettore a 4 poli
- PH A 5: connettore a 5 poli

Applicazione per tritacarne con bocca 32, modelli TL, TF, TU, TH, TZ e TX.
Arresto e avvio automatici.

La carne tritata, spinta dalla coclea, riempie una delle due forme tonde nel disco formatore. Effettuato il riempimento, un sensore arresta il funzionamento del tritacarne.

Dopo aver ruotato il disco formatore di 180°, il tritacarne si riavvia automaticamente.

La porzionatrice produce forme tonde di diametro 100 mm per 12 mm di spessore; peso indicativo 100 g.



SEMI-AUTOMATIC HAMBURGER ATTACHMENT

- PH A 4: 4 poles connector
- PH A 5: 5 poles connector

The attachment is suitable for mincers with barrel type 32, model TL, TF, TU, TH, TZ and TX.

Automatic stop and re-start.

The minced meat pushed by the worm fills one of the two round forms in the disc. When the filling is over, a proximity switch stops the mincer. By turning the disc of 180°, the mincer re-starts automatically.

The attachment produces round shaped hamburgers with a diameter of 100 mm and 12 mm of thickness, weight around 100 g.



HALBAUTOMATISCHES PORTIONIERGERÄT

- PH A 4: 4 pole anschluss
- PH A 5: 5 pole anschluss

Einsatz bei Fleischwölfe mit Schneidsatz Typ 32, TL, TF, TU, TH, TZ und TX.
Automatischer Stop und Neustart.

Das Hackfleisch wird von der Schnecke vorgeschoben und füllt eine der zwei Formen in der Scheibe ein. Nach dem Einfüllen, ein Mikroschalter stoppt den Fleischwolf.

Beim Drehen der Scheibe um 180° schaltet der Fleischwolf wieder an.

Das Portioniergerät produziert runde Formen von 100 mm Durchmesser, 12 mm Stärke und ungefähr 100 g Gewicht.



RECONSTITUEUR DE STEAK SEMI-AUTOMATIQUE

- PH A 4: connecteur 4 poles
- PH A 5: connecteur 5 poles

Application pour hachoir avec bouche 32, model TL, TF, TU, TH, TZ et TX.
Arrêt et démarrage automatiques.

La viande hachée, poussée par la vis sans fin, remplit une des deux formes ronde sur le disc. Après le remplissage, un microinterrupteur arrête le fonctionnement de l'hachoir. En tournant le disc de 180°, on démarre l'hachoir.

Le reconstituteur de steak produit des forms rondes de 100 mm de diameter, 12 mm d'épaisseur et un poids indicative de 100 g.



PORCIONADOR SEMIAUTOMATICO

- PH A 4: conector de 4 polos
- PH A 5: conector de 5 polos

Aplicación para picadores de carne con boca 32, model TL, TF, TU, TH, TZ y TX.
Parada y reencendido automáticos.

La carne picada, empujada por la cóclea, llena uno de los dos moldes redondo del disco. Despues el llenado, un sensor para la picadora.

Luego de girar el disco de 180°, la picadora se reenciende automáticamente.

El porcionador produce formas redondas de 100 mm de diámetro y 12 mm de espesor; peso indicativo: 100 g.

Specifiche tecniche / Technical specifications

	PH A
bocca, barrel, Schneidsatz, bouche, boca	32
diametro hamburger, diameter of the hamburger, Hamburgerdurchmesser, diameter de steak, diametro de la hamburguesa	100 mm
spessore hamburger, hamburger thickness, Hamburger-Stärke, epaisseur steak, espesor hamburguesa	12 mm
Peso hamburger, hamburger weight, Hamburgergewicht, Poids steak, peso hamburguesa	100 g
peso netto della porzionatrice, attachment net weight, Nettogewicht des Gerätes, poids net du reconstituteur, peso neto del porcionador	5 kg
n° hamburger al minuto, nbr of hamburgers per minute, Hamburgeranzahl pro Minute, nombre de steaks par minute, n.° de hamburguesas por minuto	30

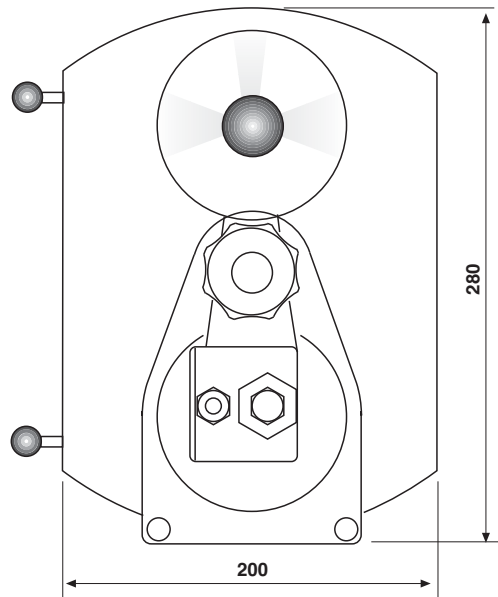
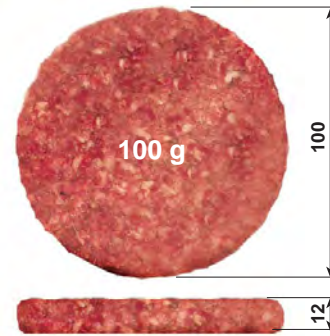

Nota: i dati del presente catalogo non sono impegnativi e potranno subire variazioni senza preavviso / Specifications and other features are subject to change without notice (02/10)