

 **OMEGA**
■ **TAGLIO FOODTECH**



TA 32A



TRITACARNE DA BANCO 32/98

Struttura in lega di alluminio lucidata e anodizzata.
Tramoggia di grandi dimensioni, rimovibile.
Bocca, coclea, volantino, bacinella (opzionale) in acciaio inossidabile AISI 304.
Versione Entreprise: 1 piastra inox e 1 coltello autoaffilanti, 1 estrattore.
Versione Unger S5 inox: bocca Ø 98, 3 piastre, 2 coltelli, 2 anelle, 1 scatola di lame di ricambio ed 1 estrattore.
Per il dettaglio, i laboratori carni, i supermercati e la ristorazione collettiva.
Macchina rispondente alla Direttiva Macchine 98/37/CEE e alle norme specifiche per i tritacarne. Comandi con dispositivo N.V.R.



TABLE TOP MINCER 32/98

Body of aluminium alloy polished and anodised.
Large-sized removable feed pan.
Barrel, worm, locking ring and meat receiving tray (optional) made of stainless steel AISI 304.
Enterprise version: 1 stainless steel holeplate and 1 self-sharpening knife, 1 extractor.
Unger version S5 stainless steel: barrel Ø 98, 3 holeplates, 2 knives, 2 rings, 1 box of spare blades and 1 extractor.
For retail, butchers, supermarkets and collective catering.
Machine complies with Machine Directive 98/37/EEC and the specific regulations for mincers. Controls with N.V.R. device



TISCH FLEISCHWÖLF 32/98

Gehäuse aus Aluminiumlegierung, poliert und eloxiert.
Abnehmbarer Einfüllschüssel.
Schnecke, Schneckengehäuse, Verschlussring, Empfangschale (optional) aus Edelstahl AISI 304.
Enterprise Ausführung: 1 Lochscheibe und 1 Messer, 1 Ausziehvorrückung.
Ausführung Unger S5 Inox: Schneidsatz Ø 98, 3 Lochscheiben, 2 Messer, 2 Einlege Ringe, 1 Schachtel Ersatzklingen und 1 Auszieher.
Für Einzelhandel, Fleischereien, Supermärkte und Großgastronomie.
Die Maschine entspricht der Maschinenrichtlinie 98/37/EWG und der Norm für Fleischwölfe. Ein-Aus Drucktasten.



HACHOIR DE COMPTOIR 32/98

Structure en alliage d'aluminium poli et anodisé.
Trémie grande taille, amovible.
Bouche, vis sans fin, écrou, plateau de réception viande en acier inoxydable AISI 304.
Version Entreprise: 1 plaque et 1 couteau, 1 extracteur.
Version Unger S5 inox: bouche Ø 98, 3 plaques, 2 couteaux, 2 anneaux, 1 boîte de lames de rechange et 1 extracteur.
Pour le détail, les laboratoires de boucherie, les supermarchés et la restauration collective.
Machine conforme à la Directive machines 98/37/CEE et aux normes spécifiques pour les hachoirs. Boutons Démarrage-Arrêt



PICADORA DE CARNE DE MESA 32/98

Estructura de aleación de aluminio lustrada y anodizada.
Tolva de grandes dimensiones, extraíble.
Boca, còclea, volante y cubeta (opcional) de acero inoxidable.
Versión Entreprise: 1 placa inoxidable, 1 cuchilla autoafilante y 1 extractor.
Versión Unger S5 inoxidable: boca Ø 98, 3 placas, 2 cuchillas, 2 anillas, 1 caja de hojas de repuesto y 1 extractor.
Para venta minorista, talleres de elaboración de carnes, supermercados y restauración colectiva.
Máquina conforme a la Directiva Máquina 98/37/CEE y a las normas específicas para las picadoras de carne. Mandos con dispositivo N.V.R.

Specifiche tecniche / Technical specifications

	TA 32A
bocca, barrel, Schneidsatz, bouche, boca	32/98
motore TF, motor TPH, Motor TPH, moteur DPH, motor TF	2,20 (3,00) kW (HP)
motore MF, motor SPH, Motor MPH, moteur EPH, motor MF	1,8 (2,5) kW (HP)
produzione, productivity, Leistung, productivité, productividad	500 kg/h
peso netto, net weight, Nettogewicht, poids net, peso neto	66 kg

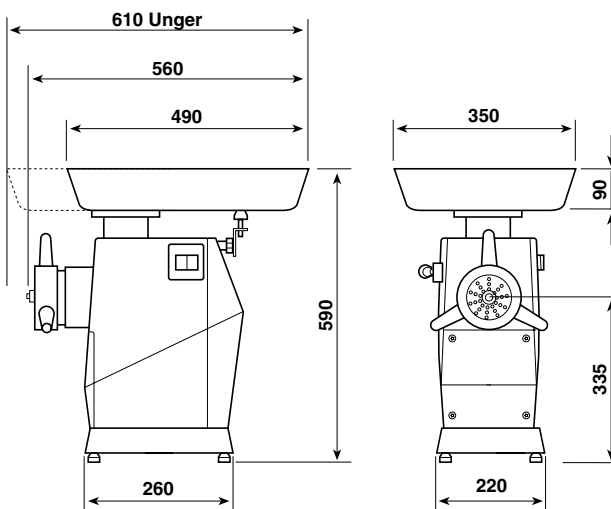

Nota: i dati del presente catalogo non sono impegnativi e potranno subire variazioni senza preavviso / Specifications and other features are subject to change without notice (01/08)