

OMEGA
TAGLIO FOODTECH



TH 32



TRITACARNE INDUSTRIALE 32/98

Su carrello con 4 ruote, di cui due frenanti; disponibile anche in versione da banco.

Carrozzeria, tramoggia, bocca, coclea e volantino in acciaio inossidabile AISI 304.

Versione Entreprise: 1 piastra inox e 1 coltello autoaffilanti, 1 estrattore.

Versione Unger S5 inox: Ø 98, 3 piastre, 2 coltelli, 2 anelli, 1 scatola di lame di ricambio ed 1 estrattore.

Per i laboratori carni, i supermercati, gli iper e la ristorazione collettiva.

Connettore per porzionatrice PH A 4.

Macchina rispondente alla Direttiva Macchine 98/37/CEE e alle norme specifiche per i tritacarne.

Comandi con dispositivo N.V.R.



INDUSTRIAL MINCER 32/98

On carriage with 4 castorwheels, two of which with brake; tabletop version also available.

Machine coating, feed pan, barrel, worm and locking ring made of stainless steel AISI 304.

Enterprise version: 1 stainless steel holeplate and 1 self-sharpening knife, 1 extractor.

Unger version S5 stainless steel: barrel Ø 98, 3 holeplates, 2 knives, 2 rings, 1 box of spare blades and 1 extractor.

For meat processing plants, supermarkets, hypermarkets and collective catering.

Connector socket for hamburger attachment PH A 4.

Machine complies with Machine Directive 98/37/EEC and the specific regulations for mincers.

Controls with N.V.R. device



INDUSTRIE-FLEISCHWÖLF 32/98

Auf Untergestell mit 4 Raeder, zwei davon mit Bremse, geliefert.

Tischausführung auch erhältlich.

Maschinengehäuse, Einfüllschüssel, Schnecke, Schneckengehäuse,

Verschlussring aus Edelstahl AISI 304.

Enterprise Ausführung: 1 Lochscheibe und 1 Messer, 1 Ausziehvorrückung.

Ausführung Unger S5 Innox: Schneidsatz Ø 98, 3 Lochscheiben, 2 Messer,

2 Einlege Ringe, 1 Schachtel Ersatzklingen und 1 Auszieher.

Für Fleischereien, Supermärkte, Hypermärkte und Großgastronomie.

Anschluss für Portioniergerät PH A 4.

Die Maschine entspricht der Maschinenrichtlinie 98/37/EWG und der Norm für Fleischwölfe.

Ein-Aus Schalter.



HACHOIR INDUSTRIEL 32/98

Sur chariot à 4 roulettes, dont deux freinantes ; disponible aussi en version comptoir.

Carrosserie, trémie, bouche, vis sans fin, écrou en acier inoxydable AISI 304.

Version Entreprise: 1 plaque et 1 couteau, 1 extracteur.

Version Unger S5 inox: bouche Ø 98, 3 plaques, 2 couteaux, 2 anneaux,

1 boîte de lames de rechange et 1 extracteur.

Pour laboratoires de boucherie, supermarchés, hypermarchés et restauration collective.

Connecteur pour reconstituteur de steak PH A 4 pôles.

Machine conforme à la Directive machines 98/37/CEE et aux normes spécifiques pour les hachoirs.

Boutons Demarrage-Arrêt.



PICADORA DE CARNE INDUSTRIAL 32/98

Con carro de 4 ruedas (dos de ellas con freno); disponible también en versión de mesa.

Carrocería de acero inoxidable AISI 304.

Boca, cóclea y volante de acero inoxidable.

Versión Entreprise: 1 placa inoxidable, 1 cuchilla autoafilante y 1 extractor.

Versión Unger S5 inoxidable: boca Ø 98, 3 placas, 2 cuchillas, 2 anillas,

1 caja de hojas de repuesto y 1 extractor.

Para talleres de elaboración de carnes, supermercados, hipermercados y restauración colectiva.

Conector para porcionador PH A 4.

Máquina conforme a la Directiva Máquina 98/37/CEE y a las normas específicas para las picadoras de carne.

Mandos con dispositivo N.V.R.

Specifiche tecniche / Technical specifications

| | TH 32 banco/tabletop/ Tisch/comptoir/ mesa | TH 32 carrello/carriage/ Untergestell/ chariot/carrito |
|---|---|---|
| bocca, barrel, Schneidsatz, bouche, boca | 32/98 | 32/98 |
| motore, motor, Motor, moteur, motor | 3 (4) kW (HP) | 3 (4) kW (HP) |
| produzione, productivity, Leistung, productivité, productividad | 1,050 kg/h | 1,050 kg/h |
| peso netto, net weight, Nettogewicht, poids net, peso neto | 132 kg | 150 kg |

Optional: porzionatrice PH A 4, hamburger attachment PH A 4, Portioniergerät PH A 4, reconstituteur de steak PH A 4, porcionador PH A 4

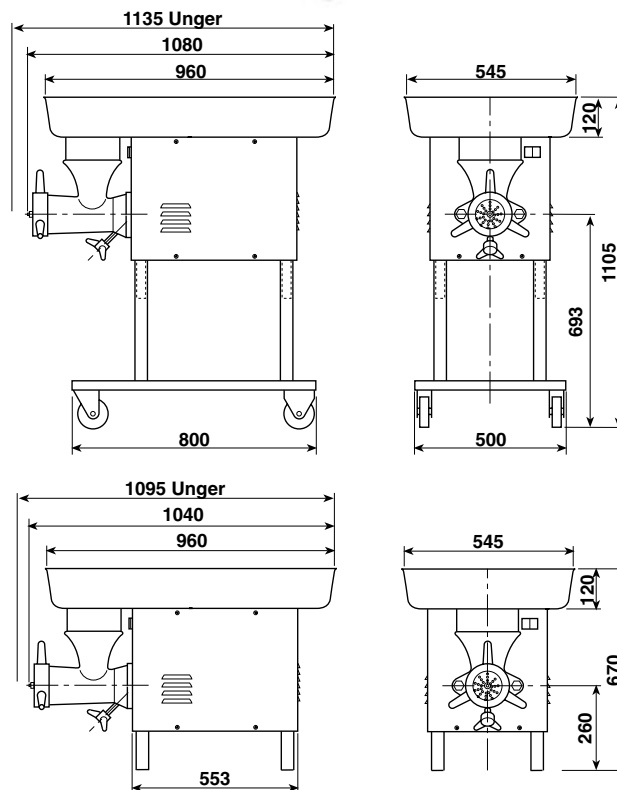

Nota: i dati del presente catalogo non sono impegnativi e potranno subire variazioni senza preavviso / Specifications and other features are subject to change without notice (01/08)