

 **OMEGA**
 **TAGLIO FOODTECH**



TL 22/S-TL 32/S

TRITACARNE DA BANCO 22/82 - 32/98
 Carrozzera, tramoggia, bocca, coclea, bacinella (opzionale) e volantino in acciaio inossidabile AISI 304. Tramoggia rimovibile.
 Versione Entreprise: 1 piastra inox e 1 coltello autoaffilanti, 1 estrattore.
 Versione Unger S3 inox: bocca Ø 82, 2 piastre, 1 coltello, 1 scatola di lame di ricambio ed 1 estrattore.
 Versione Unger S5 inox: bocca Ø 98, 3 piastre, 2 coltelli, 2 anelli, 1 scatola di lame di ricambio ed 1 estrattore.
 Per il dettaglio, i laboratori carni, i supermercati e la ristorazione collettiva. Macchine rispondenti alla Direttiva Macchine 98/37/CEE e alle norme specifiche per i tritacarne. Comandi con dispositivo N.V.R.

TABLE TOP MINCERS 22/82 - 32/98
 Machine coating, feed pan, barrel, worm, bowl (optional) and locking ring made of stainless steel AISI 304. Removable hopper.
 Enterprise version: 1 stainless steel holeplate and 1 self-sharpening knife, 1 extractor.
 Unger version S3 stainless steel: barrel Ø 82, 2 holeplates, 1 knife, 1 box of spare blades and 1 extractor.
 Unger version S5 stainless steel: barrel Ø 98, 3 holeplates, 2 knives, 2 rings, 1 box of spare blades and 1 extractor.
 For retail, butchers, supermarkets and collective catering.
 Machines comply with Machine Directive 98/37/EEC and the specific regulations for mincers. Controls with N.V.R. device.

TISCH FLEISCHWÖLFE 22/82 - 32/98
 Maschinengehäuse, Einfüllschuessel, Schnecke, Schale (optional), Schneckenengehäuse, Verschlussring aus Edelstahl AISI 304. Abnehmbarer Einfüllschüssel.
 Enterprise Ausführung: 1 Lochscheibe und 1 Messer, 1 Ausziehvorrichtung.
 Ausführung Unger S3 Inox: Schneidsatz Ø 82, 2 Lochscheiben, 1 Messer, 1 Schachtel Ersatzklingen und 1 Auszieher.
 Ausführung Unger S5 Inox: Schneidsatz Ø 98, 3 Lochscheiben, 2 Messer, 2 Einlege Ringe, 1 Schachtel Ersatzklingen und 1 Auszieher.
 Für Einzelhandel, Fleischereien, Supermärkte und Großgastronomie.
 Die Maschinen entsprechen der Maschinenrichtlinie 98/37/EWG und der Norm für Fleischwölfe. Ein-Aus Schalter.

HACHOIRS DE COMPTOIR 22/82 - 32/98
 Carrosserie, trémie, bouche, bac (option), vis sans fin, écrou en acier inoxydable AISI 304. Trémie amovible.
 Version Entreprise: 1 plaque et 1 couteau, 1 extracteur.
 Version Unger S3 inox: bouche Ø 82, 2 plaques, 1 couteau, 1 boîte de lames de rechange et 1 extracteur.
 Version Unger S5 inox: bouche Ø 98, 3 plaques, 2 couteaux, 2 anneaux, 1 boîte de lames de rechange et 1 extracteur.
 Pour le détail, les laboratoires de boucherie, les supermarchés et la restauration collective.
 Machines conformes à la Directive machines 98/37/CEE et aux normes spécifiques pour les hachoirs. Boutons Demarrage-Arrêt.

PICADORAS DE CARNE DE MESA 22/82 - 32/98
 Carrocería de acero inoxidable AISI 304.
 Boca, cóclea, volante y cubeta (opcional) de acero inoxidable. Tolva extraíble.
 Versión Entreprise: 1 placa inoxidable, 1 cuchilla autoafilante y 1 extractor.
 Versión Unger S3 inoxidable: boca Ø 82, 2 placas, 1 cuchilla, 1 caja de hojas de repuesto y 1 extractor.
 Versión Unger S5 inoxidable: boca Ø 98, 3 placas, 2 cuchillas, 2 anillas, 1 caja de hojas de repuesto y 1 extractor.
 Para venta minorista, talleres de elaboración de carnes, supermercados y restauración colectiva.
 Máquinas conformes a la Directiva Máquina 98/37/CEE y a las normas específicas para las picadoras de carne. Mandos con dispositivo N.V.R.



Specifiche tecniche / Technical specifications

	TL 22/S	TL 32/S
bocca, barrel, Schneidsatz, bouche, boca	22/82	32/98
motore TF, motor TPH, Motor TPH, moteur DPH, motor TF	0,95 (1,30) kW (HP)	2,20 (3,00) kW (HP)
motore MF, motor SPH, Motor MPH, moteur EPH, motor MF	0,95 (1,3) kW (HP)	1,8 (2,5) kW (HP)
produzione, productivity, Leistung, productivité, productividad	270 kg/h	500 kg/h
peso netto, net weight, Nettogewicht, poids net, peso neto	37 kg	66 kg

Optional (32 only): connettore a 4 poli e porzionatrice PH A 4, connector 4 poles and hamburger attachment PH A 4, 4-Pol-Anschluss und Portioniergerät PH A 4, connecteur 4 pôles et reconstituteur de steak PH A 4, conector de 4 polos y porcionador PH A 4

TL 22/S

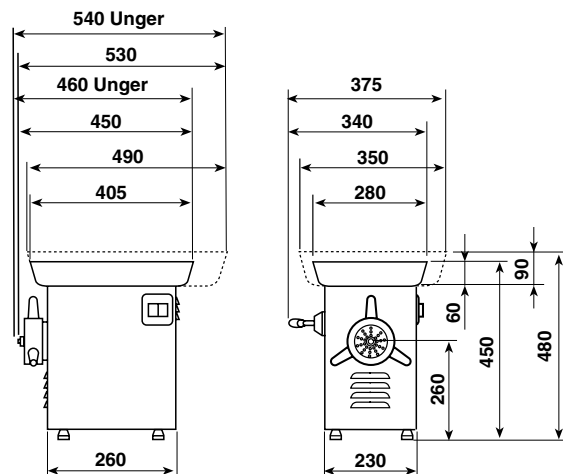

TL 32/S

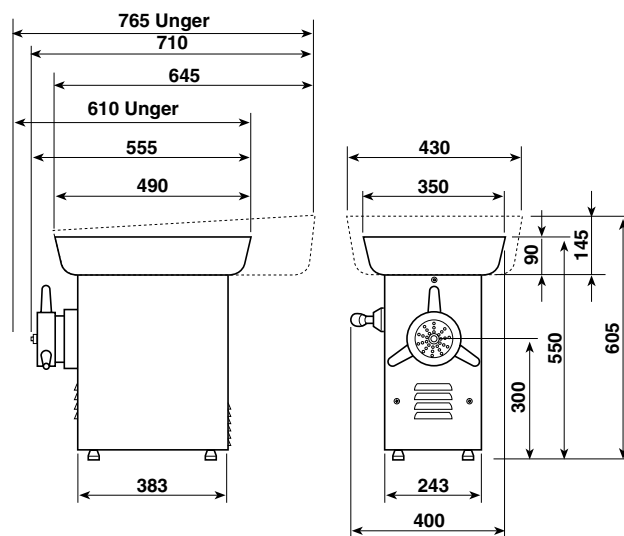

Nota: i dati del presente catalogo non sono impegnativi e potranno subire variazioni senza preavviso / Specifications and other features are subject to change without notice (01/08)