

**OMEGA**  
**TAGLIO FOODTECH**



**TZ 32**

**TRITACARNE INDUSTRIALE 32/98 CON ALIMENTAZIONE AUTOMATICA**  
Carrozzeria, bocca, coclea e volantino in acciaio inossidabile AISI 304.  
Funzione MESCOLATORE.  
Su carrello con 4 ruote di cui due frenanti. Tramoggia rimovibile.  
Due motoriduttori (macinazione e mixer).  
Bocca, coclea e volantino inox.  
Versione entreprise: 1 piastra inox e 1 coltello autoaffilanti e 1 estrattore.  
Versione Unger S5 inox: bocca Ø 98, 3 piastre, 2 coltelli, 2 anelle, 1 scatola di lame di ricambio ed 1 estrattore.  
Per i laboratori carni, i supermercati, gli iper e la ristorazione collettiva.  
Connettore per porzionatrice PH A 4.  
Macchina rispondente alla Direttiva Macchine 89/392/CEE e alle norme specifiche per i tritacarne.  
Comandi con dispositivo N.V.R.

**INDUSTRIAL MINCER 32/98 WITH AUTOMATIC FEEDING**  
Machine coating, barrel, worm and locking ring made of stainless steel AISI 304. MIXER function.  
On carriage with 4 castorwheels, two of which with brake. Removable tank.  
Two gear-motors (mincing and mixer).  
Enterprise version: 1 stainless steel holeplate and 1 self-sharpening knife and 1 extractor.  
Unger version S5 stainless steel: barrel Ø 98, 3 holeplates, 2 knives, 2 rings, 1 box of spare blades and 1 extractor.  
For meat processing plants, supermarkets, hypermarkets and collective catering.  
Connector socket for hamburger attachment PH-A 4.  
Machine complies with Machine Directive 98/37/EEC and specific regulations for mincers.  
Controls with N.V.R. device

**INDUSTRIE-FLEISCHWÖLF 32/98 MIT AUTOMATISCHER ZUFÜHRUNG**  
Maschinengehäuse, Schnecke, Schneckengehäuse, Verschlussring aus Edelstahl AISI 304. Funktion MISCHER.  
Auf Schlitten mit 4 Rädern, davon zwei mit Bremse Abnehmbare Wanne.  
Zwei Getriebemotoren (Wolf und Mixer).  
Enterprise Ausführung: 1 Lochscheibe und 1 Messer, 1 Ausziehvorrichtung.  
Ausführung Unger S5 Inox: Schneidsatz Ø 98, 3 Lochscheiben, 2 Messer, 2 Ringe, 1 Schachtel Ersatzklingen und 1 Auszieher.  
Für Fleischereien, Supermärkte, Hypermärkte und Großgastronomie.  
Anschluss für Portioniergerät PH A 4.  
Die Maschine entspricht der Maschinenrichtlinie 98/37/EWG und der Norm für Fleischwölfe.  
Ein-Aus Schalter.

**HACHOIR INDUSTRIEL 32/98 À ALIMENTATION AUTOMATIQUE**  
Carrosserie, bouche, vis sans fin, écrou en acier inoxydable AISI 304.  
Fonction MELANGEUR.  
Sur chariot à 4 roues dont deux freinantes. Trémie amovible.  
Deux motoréducteurs (malaxage et mixeur).  
Version Entreprise: 1 plaque et 1 couteau, 1 extracteur.  
Version Unger S5 inox: bouche Ø 98, 3 plaques, 2 couteaux, 2 anneaux, 1 boîte de lames de rechange et 1 extracteur.  
Pour laboratoires de boucherie, supermarchés, hypermarchés et restauration collective.  
Connecteur pour reconstituteur de steak PH A 4.  
Machine conforme à la Directive machines 98/37/CEE et aux normes spécifiques pour les hachoirs.  
Boutons Demarrage-Arrêt.

**PICADORA DE CARNE INDUSTRIAL 32/98 CON ALIMENTACIÓN AUTOMÁTICA**  
Carrocería de acero inoxidable AISI 304.  
Función MEZCLADORA.  
Con carro de 4 ruedas (dos de ellas con freno). Tolva extraíble.  
Dos motorreductores (trituration y mezcla).  
Boca, cóclea y volante inoxidable.  
Versión Entreprise: 1 placa inoxidable, 1 cuchilla autoafilante y 1 extractor.  
Versión Unger S5 inoxidable: boca Ø 98, 3 placas, 2 cuchillas, 2 anillas, 1 caja de hojas de repuesto y 1 extractor.  
Para talleres de elaboración de carnes, supermercados, hipermercados y restauración colectiva.  
Conector para porcionador PH A 4.  
Máquina conforme a la Directiva Máquina 98/37/CEE y a las normas específicas para las picadoras de carne.  
Mandos con dispositivo N.V.R.

## Specifiche tecniche / Technical specifications

	<b>TZ 32</b>
bocca, barrel, Schneidsatz, bouche, boca	32/98
motore tritacarne, mincer motor, Fleischwolfmotor, moteur hachoir, motor picadora de carne	2,2 (3,0) kW (HP)
motore mixer, mixer motor, Mixer-motor, moteur mixeur, motor mezcladora	0,37 (0,5) kW (HP)
produzione, productivity, Leistung, productivité, productividad	800 kg/h
capienza vasca, tank capacity, Inhalt der Wanne, contenance bac, capacidad cuba	25 kg
peso netto, net weight, Nettogewicht, poids net, peso neto	133 kg

**Optional:** porzionatrice PH A 4, hamburger attachment PH A 4, Portioniergerät PH A 4, reconstituteur de steak PH A 4, porcionador PH A 4

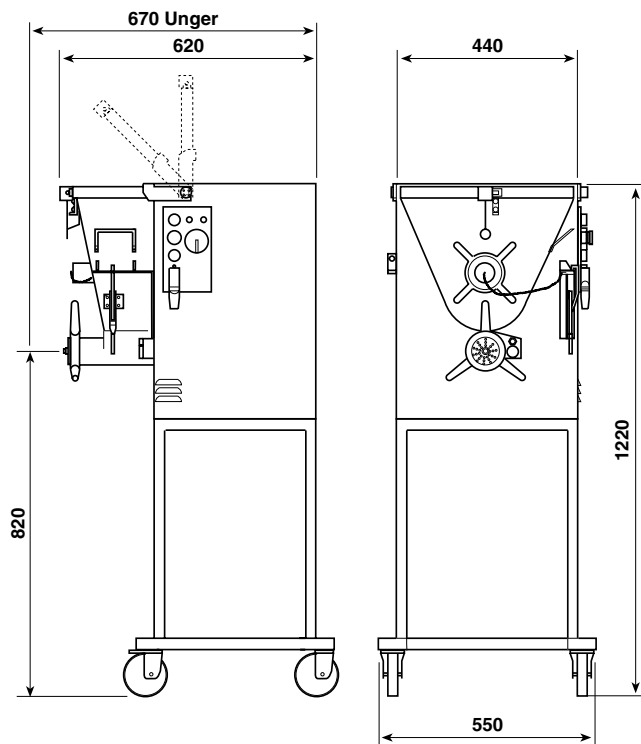

Nota: i dati del presente catalogo non sono impegnativi e potranno subire variazioni senza preavviso / Specifications and other features are subject to change without notice (01/08)