

 **OMEGA**[®]
FOODTECH



TE 22A

TRITACARNE DA BANCO 22/82
Struttura in lega di alluminio lucidata e anodizzata.
Bocca, coclea, volantino, bacinella (opzionale) in acciaio inox.
Tramoggia rimovibile.
Versione Entreprise: 1 piastra inox e 1 coltello autoaffilanti, 1 estrattore.
Versione Unger S3 inox: bocca Ø 82, 2 piastre, 1 coltello, 1 scatola di lame di ricambio ed 1 estrattore.
Per il dettaglio, i piccoli supermercati e la ristorazione collettiva.
Macchina rispondente alla Direttiva Macchine 98/37/CEE e alle norme specifiche per i tritacarne.
Comandi con dispositivo N.V.R.

TABLE TOP MINCER 22/82
*Body of aluminium alloy polished and anodised.
barrel, worm, locking ring and meat receiving tray (optional) made of stainless steel AISI 304.
Removable feed pan.
Enterprise version: 1 stainless steel holeplate and 1 self-sharpening knife, 1 extractor.
Unger version S3 stainless steel: barrel Ø 82, 2 holeplates, 1 knife, 1 box of spare blades and 1 extractor.
For retail, small supermarkets and collective catering.
Machine complies with Machine Directive 98/37/EEC and the specific regulations for mincers.
Controls with N.V.R. device*

TISCH FLEISCHWÖLF 22/82
Gehäuse aus Aluminiumlegierung, poliert und eloxiert.
Schnecke, Schneckengehäuse, Verschlussring, Empfangschale (optional) aus Edelstahl AISI 304.
Abnehmbarer Einfüllschüssel.
Enterprise Ausführung: 1 Lochscheibe und 1 Messer, 1 Ausziehvorrichtung.
Ausführung Unger S3 Inox: Schneidsatz Ø 82, 2 Lochscheiben, 1 Messer, 1 Schachtel Ersatzklingen und 1 Auszieher.
Für Lebensmitteleinzelhandel, kleine Supermärkte und Großgastronomie.
Die Maschine entspricht der Maschinenrichtlinie 98/37/EWG und der Norm für Fleischwölfe.
Ein-Aus Drucktasten.

HACHOIR DE COMPTOIR 22/82
*Structure en alliage d'aluminium poli et anodisé.
Bouche, vis sans fin, écrou, plateau de reception viande en acier inoxydable AISI 304.
Trémie amovible.
Version Entreprise: 1 plaque et 1 couteau, 1 extracteur.
Version Unger S3 inox: bouche Ø 82, 2 plaques, 1 couteau, 1 boîte de lames de rechange et 1 extracteur.
Pour le détail, les petits supermarchés et la restauration collective.
Machine conforme à la Directive machines 98/37/CEE et aux normes spécifiques pour les hachoirs.
Boutons Demarrage-Arrêt*

PICADORA DE CARNE DE MESA 22/82
Estructura de aleación de aluminio lustrada y anodizada.
Boca, cóclea, volante y cubeta (opcional) de acero inoxidable.
Tolva extraíble.
Versión Entreprise: 1 placa inoxidable, 1 cuchilla autoafilante y 1 extractor.
Versión Unger S3 inoxidable: boca Ø 82, 2 placas, 1 cuchilla, 1 caja de hojas de repuesto y 1 extractor.
Para venta minorista, pequeños supermercados y restauración colectiva.
Máquina conforme a la Directiva Máquina 98/37/CEE y a las normas específicas para las picadoras de carne.
Mandos con dispositivo N.V.R.

Specifiche tecniche / Technical specifications

	TE 22A
bocca, barrel, Schneidsatz, bouche, boca	22/82
motore, motor, Motor, moteur, motor	0,95 (1,30) kW (HP)
produzione, productivity, Leistung, productivité, productividad	270 kg/h
peso netto, net weight, Nettogewicht, poids net, peso neto	37 kg



Optional: bacinella raccogli-carne, meat receiving tray, Empfangschale, plateau de reception viande, volante y cubeta

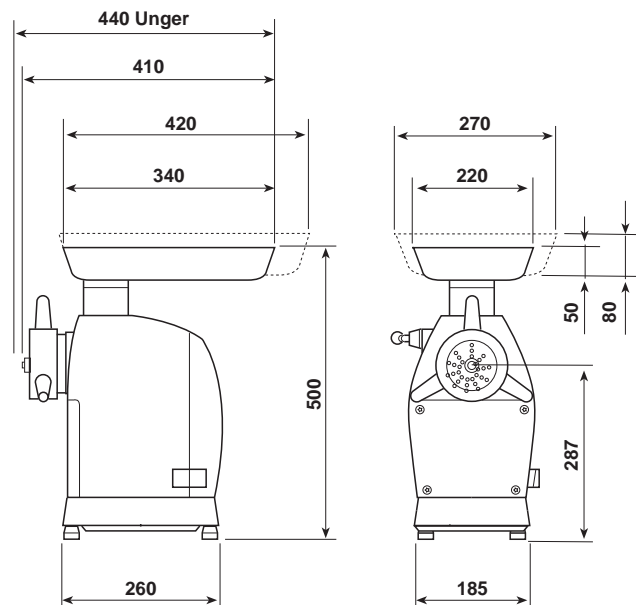

Nota: i dati del presente catalogo non sono impegnativi e potranno subire variazioni senza preavviso / Specifications and other features are subject to change without notice (02/10)